

# Pressure Vessel Design and Fabrication

Southwest Research Institute® (SwRI®) designs, analyzes, and fabricates pressure vessels subjected to both internal and external pressure loadings. Examples of these types of chambers include:

- Hyperbaric chambers
- Deck decompression chambers
- Casing collapse chambers
- Submersible hulls
- Scale models of submarine hulls
- Undersea communications and equipment chambers
- Large diameter subsea simulation chambers
- Pressure vessels for specialized research programs

## Capabilities

- Design and analysis of pressure vessels using:
  - ASME B&PV Code, Section VIII, Division 1
  - ASME B&PV Code, Section VIII, Division 2
  - ASME B&PV Code, Section VIII, Division 3
  - ASME Pressure Vessels for Human Occupancy
  - American Bureau of Shipping Rules
  - U.S. Navy Design Rules
- Design of structures and load frames using AISC “Specification for the Design, Fabrication, and Erection of Structural Steel for Buildings”
- Fabrication
  - ASME B&PV Code, Section VIII, Division 1
  - ASME B&PV Code, Section VIII, Division 2
  - ASME B&PV Code, Section VIII, Division 3
  - ASME Pressure Vessels for Human Occupancy
  - American Bureau of Shipping Rules
  - U.S. Navy Fabrication Procedures

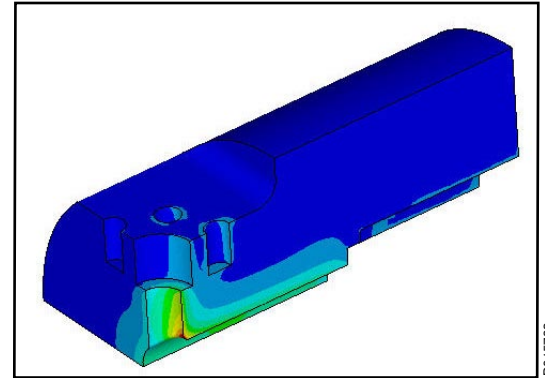

D015783



DE137984

50-in ID, 24-ft long, 6,500-psi deep ocean test chamber at SwRI



D015304\_7696

*SwRI designed, built and tested pressure hulls for U.S. Navy next-generation submarine rescue system*



D015113\_0069

## KEYWORDS

Pressure Vessel

Submersible Hulls

Finite Element Analysis

Stress Analysis

Buckling Analysis

Pressure Vessel  
Fabrication

Structural Fabrication

## Experience

- Examples of pressure vessels designed and fabricated:
  - Hull for U.S. Navy next-generation submarine rescue system
  - Quarter-scale model of U.S. Navy Seawolf Class attack submarine
  - Casing collapse chambers with internal pressure ratings of 30,000 psig, 16-inch inside diameter, and 120-inch inside working length
  - Research vessel with sapphire viewports with pressure rating of 50,000 psig
  - Hyperbaric chambers
  - 6,500 msw research submarine (design and fabrication in progress)



SwRI built the Kokanee submarine, the largest unmanned sub in the world (roughly 100 feet long and 10 feet in diameter), to simulate the acoustic and hydrodynamic characteristics of the Seawolf Class attack submarine. All structures, foundations, and control planes were designed and fabricated at SwRI.

D0000761



Benefiting government,  
industry and the public  
through innovative  
science and technology

Undersea Electronics  
Equipment Chamber



D015784



Southwest Research Institute is an independent, nonprofit, applied engineering and physical sciences research and development organization using multidisciplinary approaches to problem solving. The Institute occupies 1,200 acres in San Antonio, Texas, and provides nearly two million square feet of laboratories, test facilities, workshops, and offices for more than 3,000 employees who perform contract work for industry and government clients.

We welcome  
your inquiries.

For additional  
information,  
please contact: