

Southwest Research Institute® (SwRI®) has over 15 years of experience in the research, design and development of networks and network-based systems. With this extensive background in networks, coupled with real-time systems focus, SwRI is a pioneer in bringing networking technology to airborne and space platforms. SwRI is also conducting research and development in reconfigurable communications architectures for space applications.

Aircraft Vehicle Networks and Flight Test Systems

SwRI is applying networking technology to aircraft and aviation flight test systems using innovative combinations of open standards. Some features and capabilities of systems developed by SwRI include:

- Real-time data acquisition, recording and telemetry
- IEEE-1588 precision network-based time synchronization
- 10/100/1000 copper/fiber Ethernet
- Multicast UDP/IP data transport
- Total sensor data rates exceeding 500 Mbps
- Automated and centralized network management systems
- Integrated health and status monitoring
- Flight-ruggedized equipment

Precision Network-Based Time Synchronization

Variable transport latencies and inadequate time synchronization have hindered the deployment of network-based solutions in applications that require real-time response. The very high precision time synchronization capabilities provided by emerging standards such as IEEE-1588 have made the advantages of network-centric designs available to real-time and high data throughput applications. Advantages to network-based time synchronization include:

- Requires only one additional Ethernet cable and switch port to add the time source to the network
- Does not require a separate legacy time synchronization bus (e.g., IRIG-B) connection to each device
- Provides for sub-microsecond network-wide time synchronization

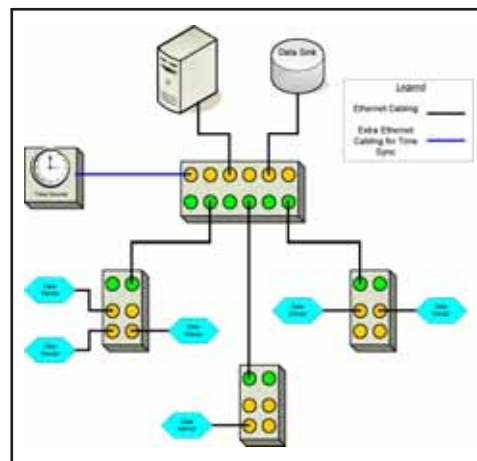

Example of network-based time synchronization

Space Internetworking

SwRI is well positioned to provide space-based networking solutions, based on extensive experience and core competencies in:

- Network-centric systems and network security
- Flight software development
- Radiation-hardened space avionics design and fabrication

An area of growing importance in space communications is the use of standard networking software to support integration of spacecraft systems with external networks. SwRI is developing integration protocols for SpaceWire, a new standard for onboard switched networks. SwRI has developed the SpaceWire Link Interface Module (SLIM), a rugged cPCI module suitable for harsh space environments. SpaceWire has many potential applications including:

- An enabling technology for Responsive Space (e.g., support for rapid integration of components)
- Vehicle network for manned spacecraft such as NASA's Crew Exploration Vehicle (CEV)
- Networking infrastructure for lunar surface research habitation modules

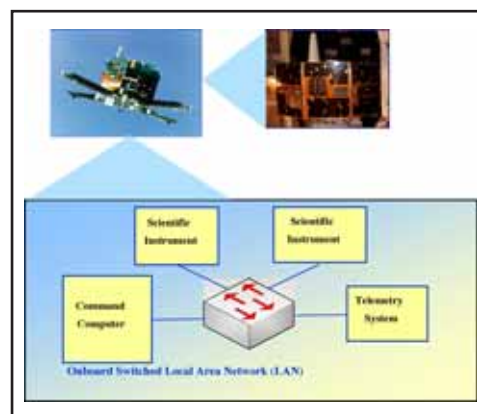

Sample spacecraft switched local area network



D015476

D015478

Software Defined Radio (SDR) for Reconfigurable Communications

During the last decade, programmable digital radio systems have been replacing fixed analog radio systems as programmable hardware components have become more capable, inexpensive and available, and wireless communications applications have demanded reusable, reconfigurable and flexible radios. Consequently, an evolving technology known as Software Defined Radio (SDR) has emerged.

- Traditional digital radio systems used application-specific integrated circuits (ASICs) and digital signal processors (DSPs).
- An SDR system implements many internal (baseband) operations with software or firmware.
- As hardware components evolve, future SDR systems may also allow programmable radio frequency (RF) bands within the RF section.

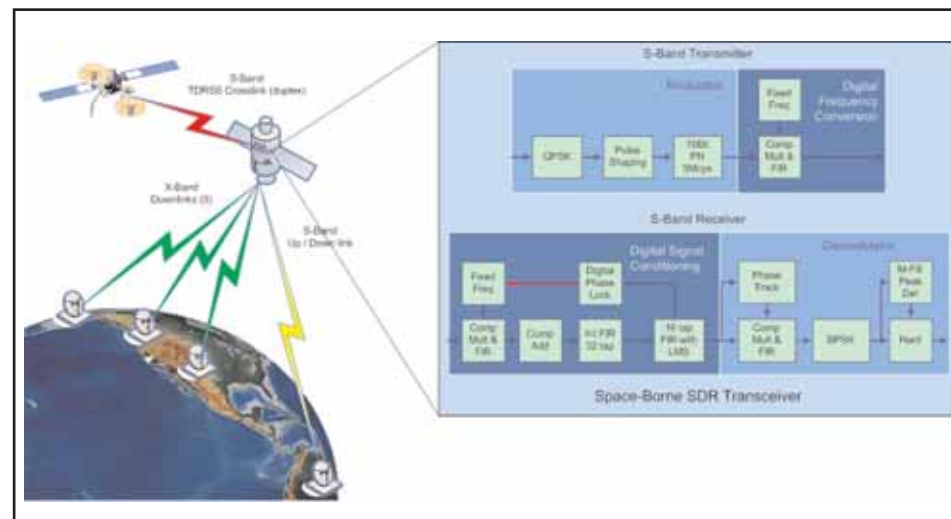

SwRI is a leader in researching flexible SDR communication designs for space applications

- SDR technologies allow fewer devices to support communications requirements, reducing size, weight and power.
- SwRI has developed SDR platforms, waveforms, transceivers, and SDR satellite communication terminals.



Southwest Research Institute is an independent, nonprofit, applied engineering and physical sciences research and development organization using multidisciplinary approaches to problem solving. The Institute occupies more than 1,200 acres in San Antonio, Texas, and provides nearly two million square feet of laboratories, test facilities, workshops, and offices for more than 3,000 employees who perform contract work for industry and government clients.

We welcome your inquiries.
For additional information, please contact:

Aircraft Vehicle Networks

Myron Moodie
Principal Engineer
(210) 522-5557 • Fax (210) 522-5499
myron.moodie@swri.org

Space Internetworking

Robert Klar
Group Leader, R&D
(210) 522-5052 • Fax (210) 522-5499
robert.klar@swri.org

Software Defined Radio

Michael Moore
Principal Engineer
(210) 522-5944 • Fax (210) 522-5499
michael.moore@swri.org

Communications & Embedded Systems Department
Automation & Data Systems Division
Southwest Research Institute
6220 Culebra • P.O. Drawer 28510
San Antonio, Texas 78228-0510

